



SLIDING DOOR  
SYSTEM

TRACK-PRO

TRACK-PRO

The New Sliding Door System

A Silent Sliding Door For  
Your Home



- Gentle and smooth door opening and closing thanks to patented soft-closing mechanism
- Double-roller device on damper trigger provides smooth and stable movement and avoids roller disengagement
- Buffer integrated on damper catching device



Quietness



Intelligence



Durability



Eco-Friendliness

# TRACK-PRO

CS Series Soft-close Sliding Door System

## PRODUCT



## DESCRIPTION

- Gentle and smooth door opening and closing thanks to patented damper design
- Effective catching mechanism prevents door disengagement
- Double-roller deviced on damper trigger provides smooth and stable movement and avoids roller disengagement
- Stepless adjustment(35-39mm) on guiding rollers interval
- Bottom roller adjustment range:0-12mm
- Damper trigger height adjustment up to 6mm

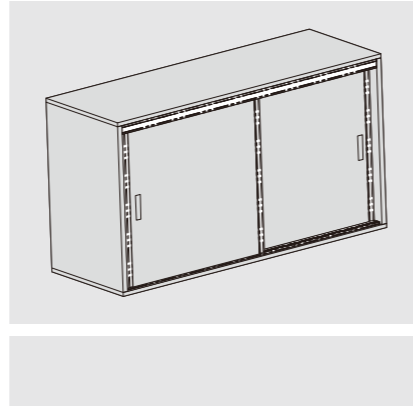

## CS Two-way Soft-close, Invisible Bottom Roller, for Aluminum Frame Door

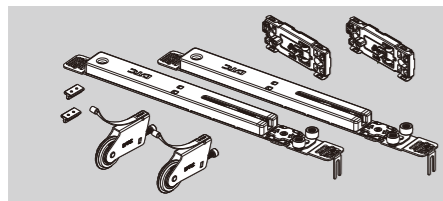

Kit Package			
Door Weight(KG)	Item No.	Set/ctn	
5~15	0CS001A	10	
15~30	0CS001B	10	
30~50	0CS001C	10	

0CS001 Kit Package includes:

2 x damper	2 x damper trigger	2 x bottom roller	2 x dowel

1	Damper (for Alu Door) / Industrial package		
	Door Weight(KG)	Item No.	Pcs/ctn
	5~15	CSHCA1	100
	15~30	CSHCA2	100
	30~50	CSHCA3	100

2	Damper trigger / Industrial package	
	Item No.	Pcs/ctn
	CSBDA	200

3	Bottom Roller / Industrial package	
	Item No.	Pcs/ctn
	CSXLA	100

4	Dowel / Industrial package	
	Item No.	Pcs/ctn
	CSXW01	5000

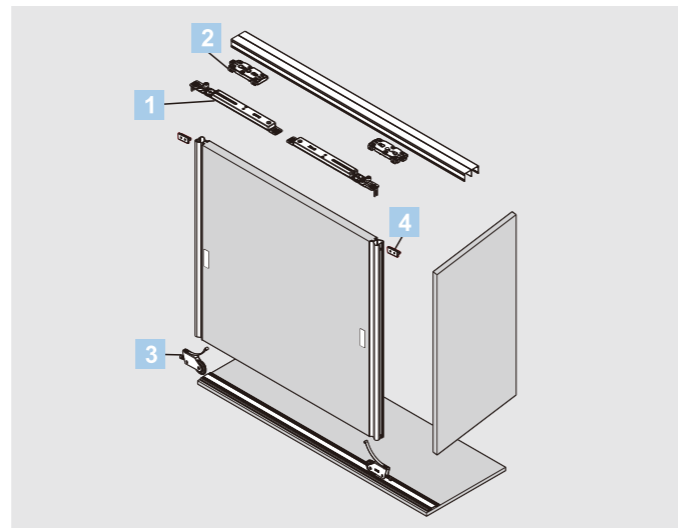

## PLANNING

### Sliding Door Installation Dimensions(mm)

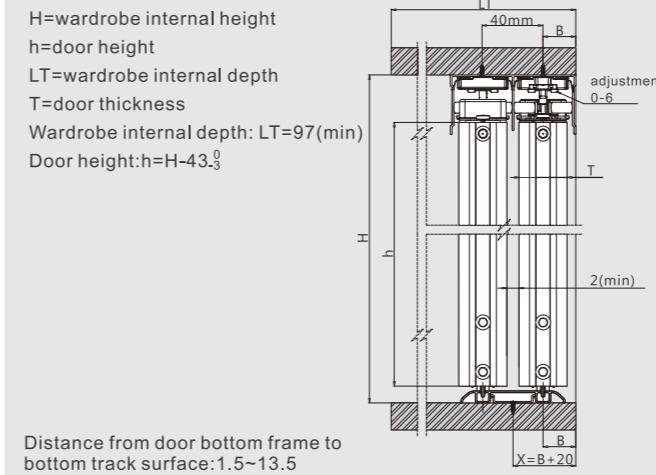

### Damper Trigger Installation Dimensions(mm)

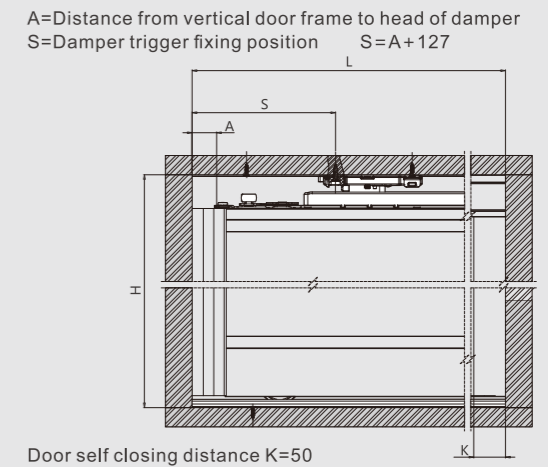

### Sliding Door Installation Dimensions(mm)

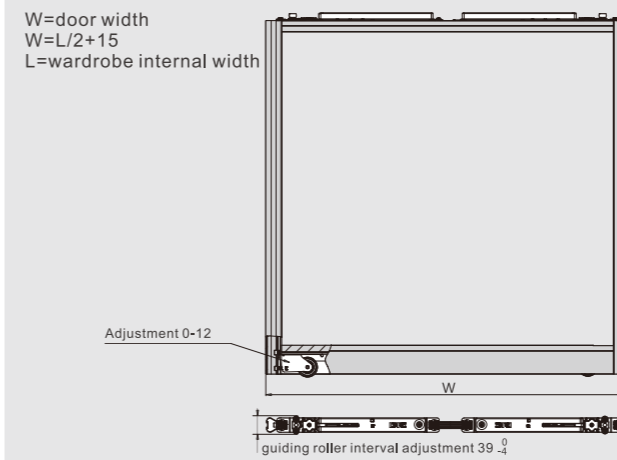

### Top Track Installation Dimensions(mm)

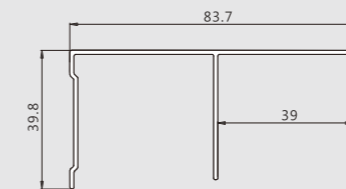

Top Track / Industrial package	
Silver white ( F98 )	
Item No.	Pcs/ctn
CSDG01	5
Length : 6meters	

### Bottom Track Installation Dimensions(mm)

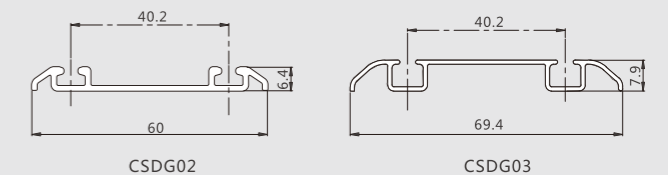

Bottom Track / Industrial package	
Silver white ( F98 )	
Item No.	Pcs/ctn
CSDG02	10
CSDG03	10
Length : 6meters	

# TRACK-PRO

CS Series Soft-close Sliding Door System

## PRODUCT



## DESCRIPTION

- Gentle and smooth door opening and closing thanks to patented damper design
- Effective catching mechanism prevents door disengagement
- Double-roller deviced on damper trigger provides smooth and stable movement and avoids roller disengagement
- Stepless adjustment(35-39mm) on guiding rollers interval
- Bottom roller adjustment range:0-12mm
- Damper trigger height adjustment up to 6mm

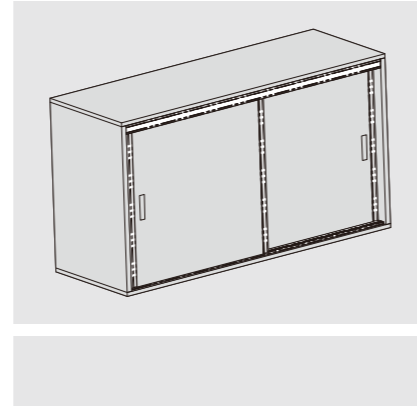

## CS One-way Soft-close, Invisible Bottom Roller, for Aluminum Frame Door

Kit Package			
Door Weight(KG)	Item No.	Set/ctn	
5~15	0CS002A	10	
15~30	0CS002B	10	
30~50	0CS002C	10	

0CS002 Kit Package includes:

1 x damper	1 x top roller	1 x damper trigger	2 x bottom roller	1 x dowel

1 Damper(for Alu Door) / Industrial package			
Door Weight(KG)	Item No.	Pcs/ctn	
5~15	CSHCA1	100	
15~30	CSHCA2	100	
30~50	CSHCA3	100	

2 Damper trigger / Industrial package	
Item No.	Pcs/ctn
CSBDA	200

3 Bottom Roller / Industrial package	
Item No.	Pcs/ctn
CSXLA	100

4 Dowel / Industrial package	
Item No.	Pcs/ctn
CSXW01	5000

5 Top Roller / Industrial package	
Item No.	Pcs/ctn
CSSL-JA	500

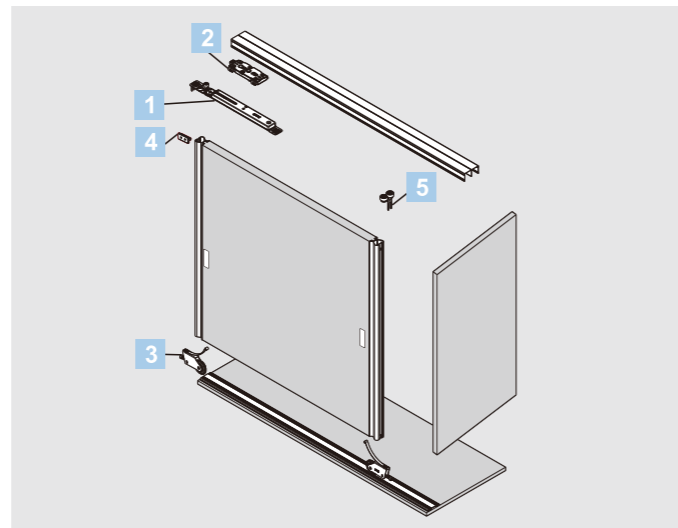

## PLANNING

### Sliding Door Installation Dimensions(mm)

H=wardrobe internal height  
 h=door height  
 LT=wardrobe internal depth  
 T=door thickness  
 Wardrobe internal depth: LT=97(min)  
 Door height:h=H-43 $\frac{3}{4}$

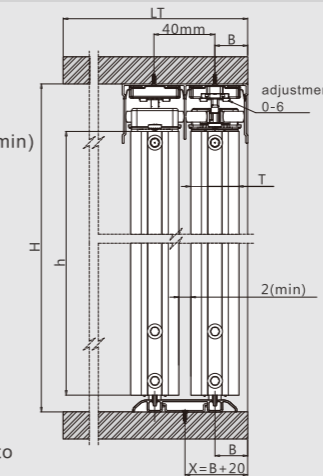

Distance from door bottom frame to bottom track surface:1.5~13.5

### Sliding Door Installation Dimensions(mm)

W=door width  
 W=L/2+15  
 L=wardrobe internal width

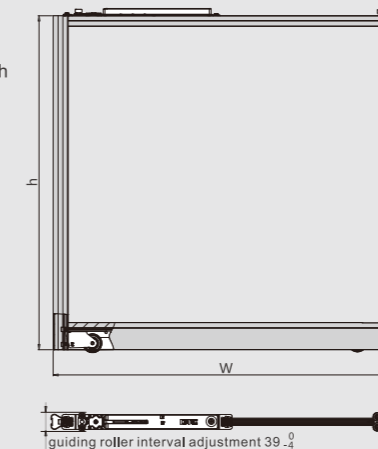

### Top Track Installation Dimensions(mm)

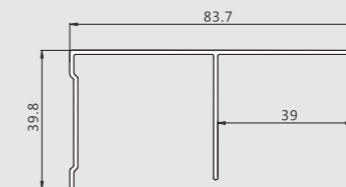

Top Track / Industrial package  
 Silver white ( F98 )

Item No.	Pcs/ctn
CSDG01	5
Length : 6meters	

### Damper Trigger Installation Dimensions(mm)

A=Distance from vertical door frame to head of damper  
 S=Damper trigger fixing position S=A+127

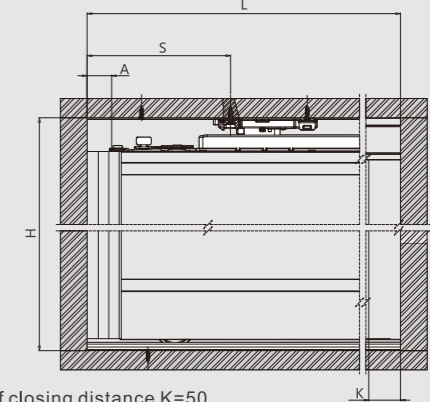

Door self closing distance K=50

### Bottom Track Installation Dimensions(mm)

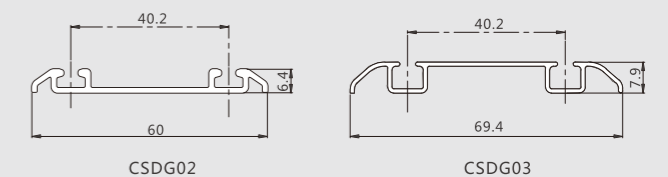

Bottom Track / Industrial package  
 Silver white ( F98 )

Item No.	Pcs/ctn
CSDG02	10
CSDG03	10
Length : 6meters	

# TRACK-PRO

## CS Series Soft-close Sliding Door System

### PRODUCT



### DESCRIPTION

- Gentle and smooth door opening and closing thanks to patented damper design
- Effective catching mechanism prevents door disengagement
- Double-roller deviced on damper trigger provides smooth and stable movement and avoids roller disengagement
- Sufficient door height adjustments, efficient and convenient adjustments thanks to unique eccentric disc design on bottom roller
- 9mm sprung adjustment, and 4mm eccentric adjustment (totally adjustment 9mm)
- Stepless adjustment(35-39mm) on guiding rollers interval
- Damper trigger height adjustment up to 6mm

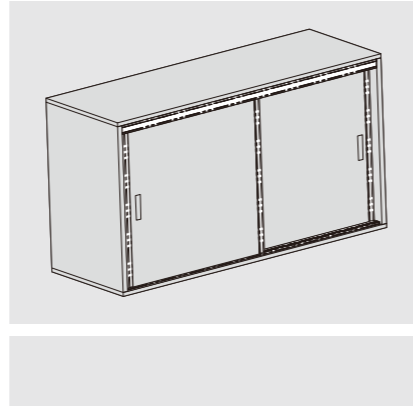

### CS Two-way Soft-close, Insert-type Bottom Roller, for Wood Door

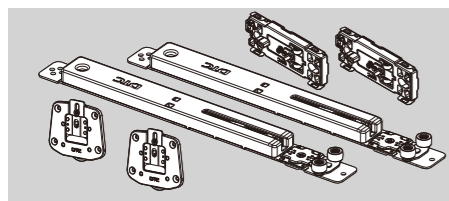

Kit Package			
Door Weight(KG)	Item No.	Set/ctn	
5~15	0CS003A	10	
15~30	0CS003B	10	
30~50	0CS003C	10	

#### 0CS003 Kit Package includes:

2 x damper	2 x damper trigger	2 x insert-type bottom roller

#### 1 Damper (for Wood Door) / Industrial package

Door Weight(KG)	Item No.	Pcs/ctn
5~15	CSHCB1	100
15~30	CSHCB2	100
30~50	CSHCB3	100

#### 2 Damper trigger / Industrial package

Item No.	Pcs/ctn
CSBDA	200

#### 3 Insert-type Bottom Roller / Industrial package

Item No.	Pcs/ctn
CSYLA	200

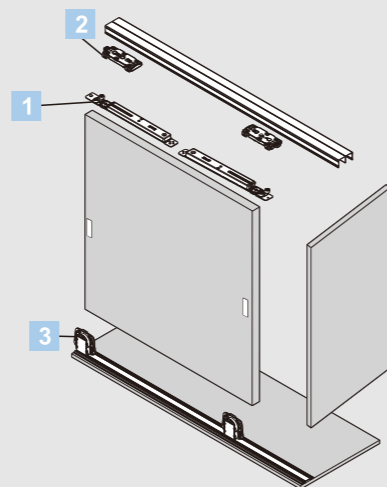

### PLANNING

#### Sliding Door Installation Dimensions(mm)

- H=wardrobe internal height
- h=door height
- LT=wardrobe internal depth
- T=door thickness
- Wardrobe internal depth: LT=95(min)
- Door height:h=H-43.8
- Door thickness:T=16~34

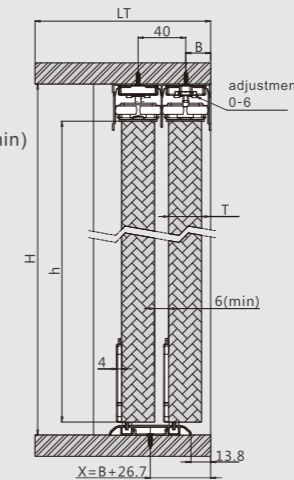

Distance from door bottom to bottom track surface:2.5~12

#### Sliding Door Installation Dimensions(mm)

- W=door width
- W=L/2+15
- L=wardrobe internal width

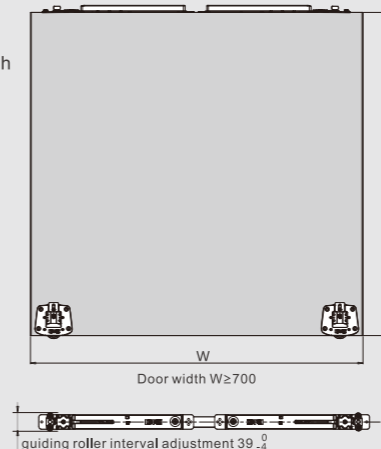

#### Top Track Installation Dimensions(mm)

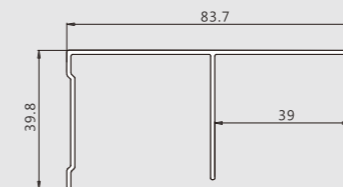

Top Track / Industrial package  
Silver white ( F98 )

Item No.	Pcs/ctn
CSDG01	5

Length : 6meters

#### Damper Trigger Installation Dimensions(mm)

- A=Distance from vertical door frame to head of damper
- S=Damper trigger fixing position S=A+109

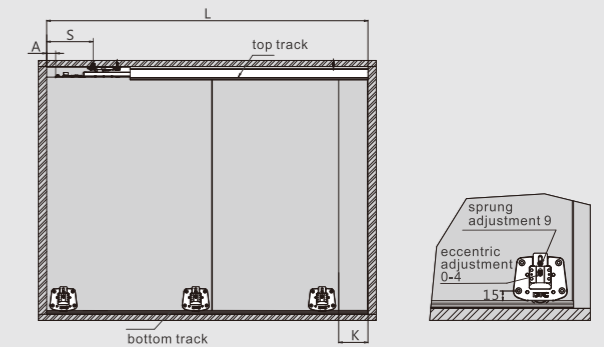

Door self closing distance K=50

#### Door Drilling Dimensions(mm)

T=Door thickness

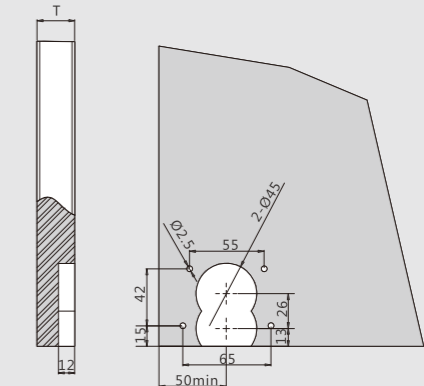

#### Bottom Track Installation Dimensions(mm)

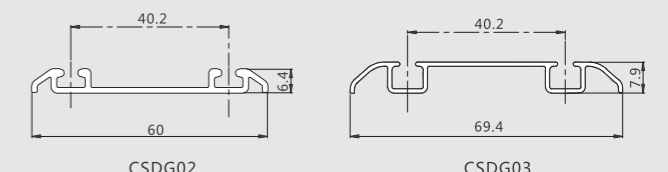

Bottom Track / Industrial package  
Silver white ( F98 )

Item No.	Pcs/ctn
CSDG02	10
CSDG03	10

Length : 6meters

# TRACK-PRO

CS Series Soft-close Sliding Door System

## PRODUCT



## DESCRIPTION

- Gentle and smooth door opening and closing thanks to patented damper design
- Effective catching mechanism prevents door disengagement
- Double-roller deviced on damper trigger provides smooth and stable movement and avoids roller disengagement
- Sufficient door height adjustments, efficient and convenient adjustments thanks to unique eccentric disc design on bottom roller
- 9mm sprung adjustment, and 4mm eccentric adjustment (totally adjustment 9mm)
- Stepless adjustment(35-39mm) on guiding rollers interval
- Damper trigger height adjustment up to 6mm

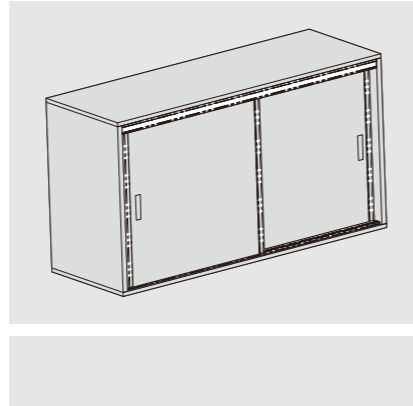

## CS One-way Soft-close, Insert-type Bottom Roller, for Wood Door

Kit Package			
Door Weight(KG)	Item No.	Set/ctn	
5~15	0CS004A	10	
15~30	0CS004B	10	
30~50	0CS004C	10	

0CS004 Kit Package includes:

1 x damper	1 x damper trigger	2 x insert-type bottom roller	1 x top roller

	Damper(for Wood Door) / Industrial package			Damper trigger / Industrial package	
Door Weight(KG)	Item No.	Pcs/ctn	Item No.	Pcs/ctn	
5~15	CSHCB1	100	CSBDA	200	
15~30	CSHCB2	100			
30~50	CSHCB3	100			

	Insert-type Bottom Roller / Industrial package	
Item No.	Pcs/ctn	
CSYLA	200	

	Top Roller / Industrial package	
Item No.	Pcs/ctn	
CSSL-PA	200	

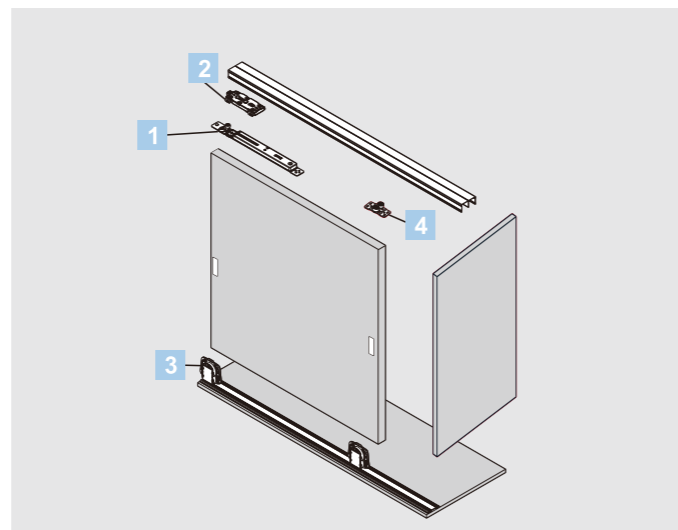

## PLANNING

### Sliding Door Installation Dimensions(mm)

H=wardrobe internal height  
 h=door height  
 LT=wardrobe internal depth  
 T=door thickness  
 Wardrobe internal depth: LT=95(min)  
 Door height:h=H-43.3  
 Door thickness:T=16~34

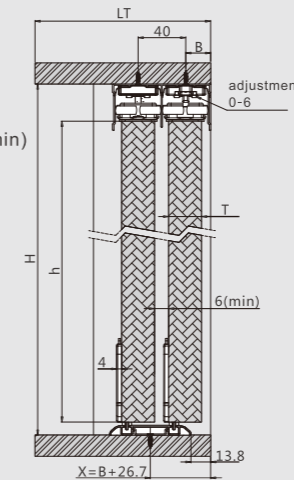

Distance from door bottom to bottom track surface:2.5~12

### Sliding Door Installation Dimensions(mm)

W=door width  
 W=L/2+15  
 L=wardrobe internal width

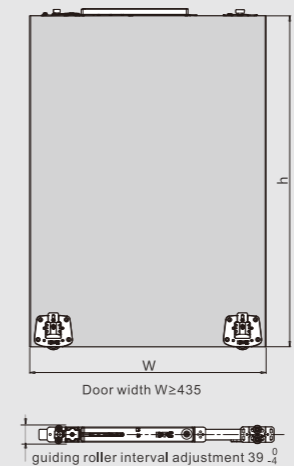

### Top Track Installation Dimensions(mm)

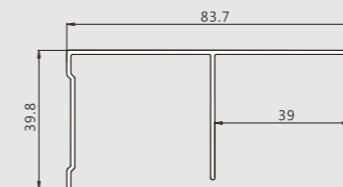

Top Track / Industrial package  
 Silver white ( F98 )

Item No.	Pcs/ctn
CSDG01	5

Length : 6meters

### Damper Trigger Installation Dimensions(mm)

A=Distance from vertical door frame to head of damper  
 S=Damper trigger fixing position S=A+109

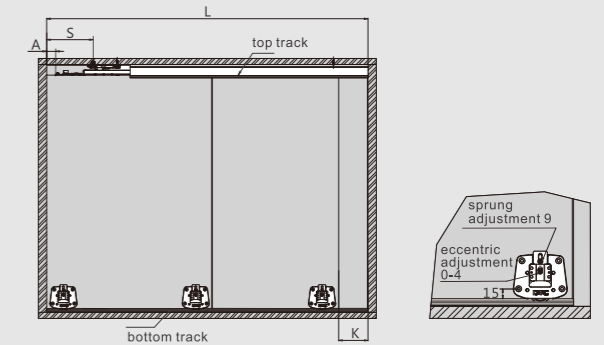

Door self closing distance K=50

### Door Drilling Dimensions(mm)

T=Door thickness

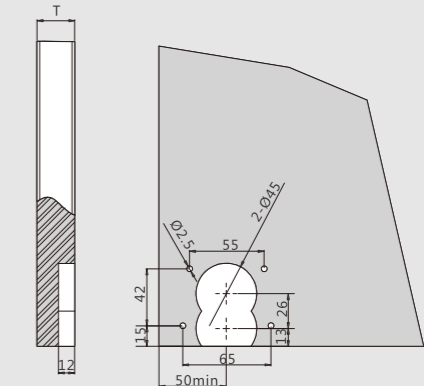

### Bottom Track Installation Dimensions(mm)

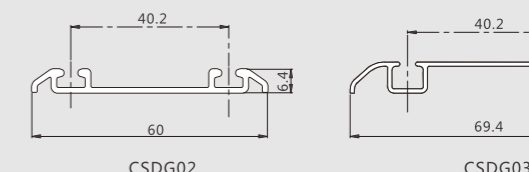

Bottom Track / Industrial package  
 Silver white ( F98 )

Item No.	Pcs/ctn
CSDG02	10
CSDG03	10

Length : 6meters

# TRACK-PRO

## CS Series Soft-close Sliding Door System

### PRODUCT



### DESCRIPTION

- Gentle and smooth door opening and closing thanks to patented damper design
- Effective catching mechanism prevents door disengagement
- Double-roller deviced on damper trigger provides smooth and stable movement and avoids roller disengagement
- Sufficient door height adjustments, efficient and convenient adjustments thanks to unique eccentric disc design on bottom roller
- 15mm sprung adjustment, and 5mm eccentric adjustment (totally adjustment 20mm)
- Stepless adjustment(35-39mm) on guiding rollers interval
- Damper trigger height adjustment up to 6mm

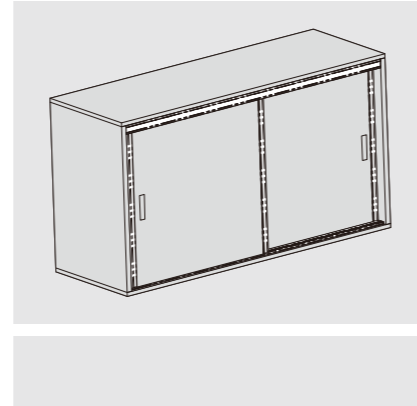

### CS Two-way Soft-close, Surface-mount Bottom Roller, for Wood Door

Kit Package			
Door Weight(KG)	Item No.	Set/ctn	
5~15	0CS005A	10	
15~30	0CS005B	10	
30~50	0CS005C	10	

#### 0CS005 Kit Package includes:

2 x damper	2 x damper trigger	2 x surface-mount bottom roller

	Damper(for Wood Door) / Industrial package
--	--

Door Weight(KG)	Item No.	Pcs/ctn
5~15	CSHCB1	100
15~30	CSHCB2	100
30~50	CSHCB3	100

	Damper trigger / Industrial package
--	-------------------------------------

Item No.	Pcs/ctn
CSBDA	200

	Surface-mount Bottom Roller Industrial package
--	--

Item No.	Pcs/ctn
CSMLA	100

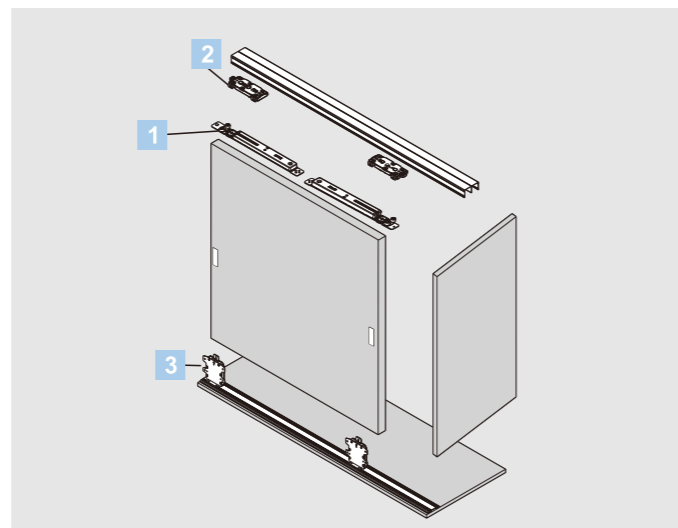

### PLANNING

#### Sliding Door Installation Dimensions(mm)

H=wardrobe internal height  
 h=door height  
 LT=wardrobe internal depth  
 T=door thickness  
 Wardrobe internal depth: LT=97(min)  
 Door height:h=H-43.3  
 Door thickness:T=10~24

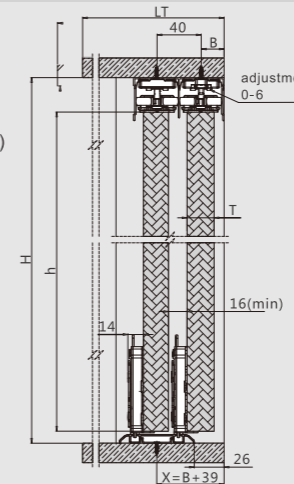

Distance from door bottom to bottom track surface:1.5~16.5

#### Sliding Door Installation Dimensions(mm)

W=door width  
 W=L/2+15  
 L=wardrobe internal width

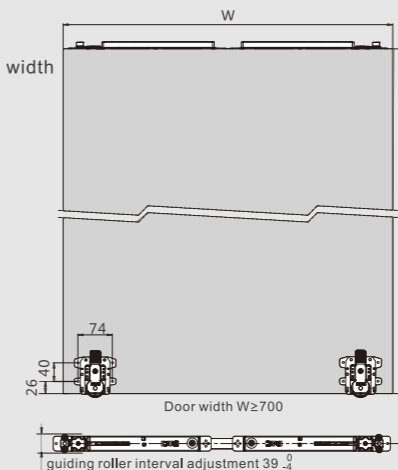

#### Top Track Installation Dimensions(mm)

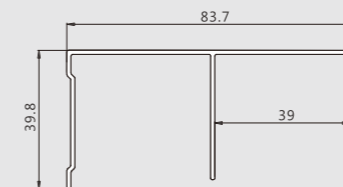

Top Track / Industrial package  
 Silver white ( F98 )

Item No.	Pcs/ctn
CSDG01	5

Length : 6meters

#### Damper Trigger Installation Dimensions(mm)

A=Distance from vertical door frame to head of damper  
 S=Damper trigger fixing position S=A+109

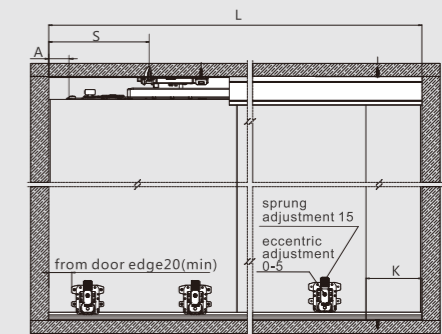

Door self closing distance K=50

#### Bottom Track Installation Dimensions(mm)

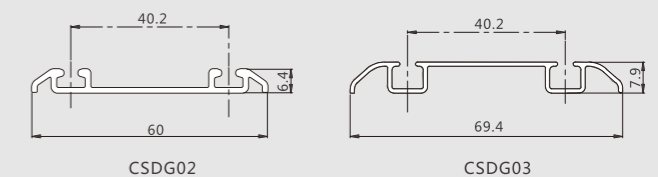

Bottom Track / Industrial package  
 Silver white ( F98 )

Item No.	Pcs/ctn
CSDG02	10
CSDG03	10

Length : 6meters

# TRACK-PRO

## CS Series Soft-close Sliding Door System

### PRODUCT



### DESCRIPTION

- Gentle and smooth door opening and closing thanks to patented damper design
- Effective catching mechanism prevents door disengagement
- Double-roller deviced on damper trigger provides smooth and stable movement and avoids roller disengagement
- Sufficient door height adjustments, efficient and convenient adjustments thanks to unique eccentric disc design on bottom roller
- 15mm sprung adjustment, and 5mm eccentric adjustment (totally adjustment 20mm)
- Stepless adjustment(35-39mm) on guiding rollers interval
- Damper trigger height adjustment up to 6mm

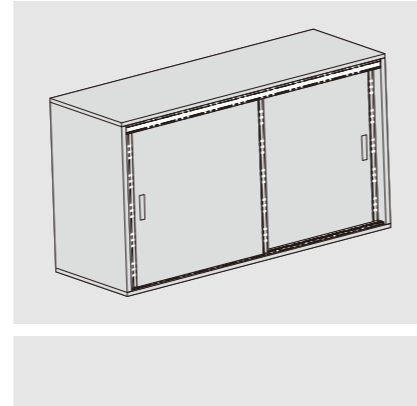

### CS One-way Soft-close, Surface-mount Bottom Roller, for Wood Door

Kit Package			
Door Weight(KG)	Item No.	Set/ctn	
5~15	0CS006A	10	
15~30	0CS006B	10	
30~50	0CS006C	10	

0CS006 Kit Package includes:

1 x damper	1 x damper trigger	2 x surface-mount bottom roller	1 x top roller

	Damper(for Wood Door) / Industrial package			Damper trigger / Industrial package	
Door Weight(KG)	Item No.	Pcs/ctn	Item No.	Pcs/ctn	
5~15	CSHCB1	100	CSBDA	200	
15~30	CSHCB2	100			
30~50	CSHCB3	100			

	Surface-mount Bottom Roller Industrial package	
Item No.	Pcs/ctn	
CSMLA	100	

	Top Roller / Industrial package	
Item No.	Pcs/ctn	
CSSL-PA	200	

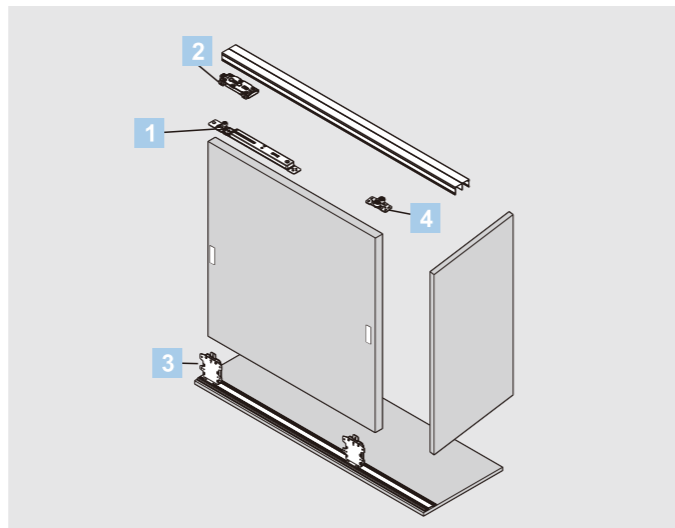

### PLANNING

#### Sliding Door Installation Dimensions(mm)

H=wardrobe internal height  
h=door height  
LT=wardrobe internal depth  
T=door thickness  
Wardrobe internal depth: LT=97(min)  
Door height:h=H-43.3  
Door thickness:T=10~24

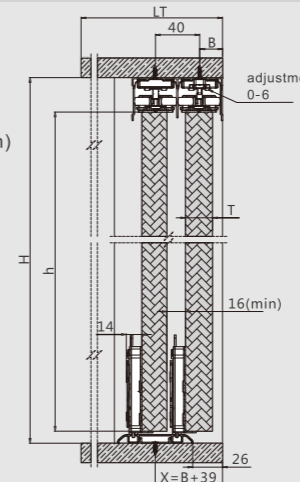

Distance from door bottom frame to bottom track surface: 1.5~16.5

#### Sliding Door Installation Dimensions(mm)

W=door width  
W=L/2+15  
L=wardrobe internal width

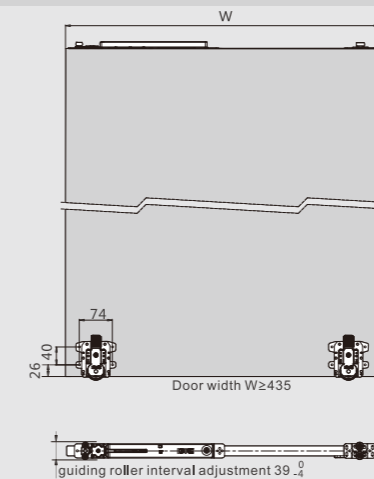

#### Damper Trigger Installation Dimensions(mm)

A=Distance from vertical door frame to head of damper  
S=Damper trigger fixing position S=A+109

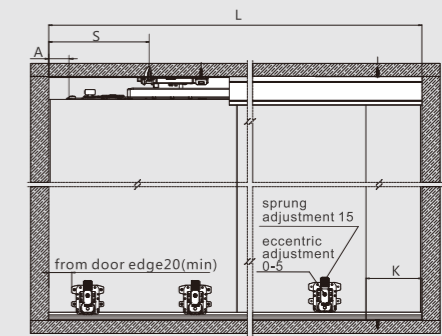

Door self closing distance K=50

#### Top Track Installation Dimensions(mm)

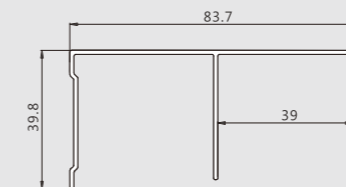

Top Track / Industrial package  
Silver white ( F98 )

Item No.	Pcs/ctn
CSDG01	5

Length : 6meters

#### Bottom Track Installation Dimensions(mm)

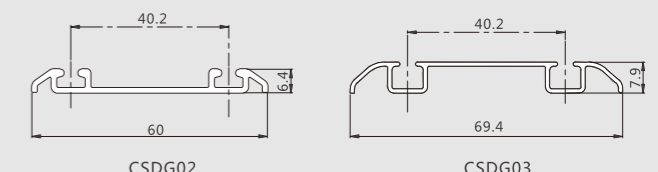

Bottom Track / Industrial package  
Silver white ( F98 )

Item No.	Pcs/ctn
CSDG02	10
CSDG03	10

Length : 6meters

# TRACK-PRO

CS Series Sliding Door Top Roller Options

## ORDER INFORMATION

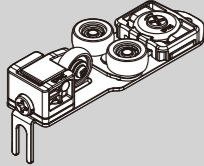
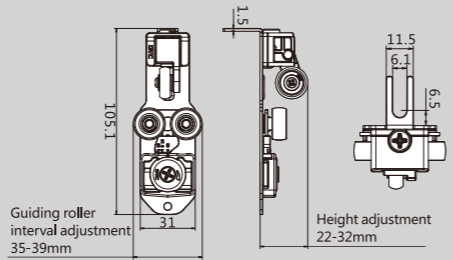
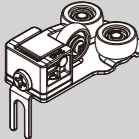
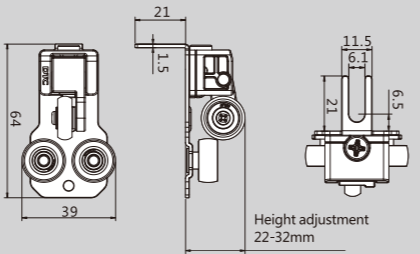
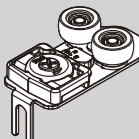
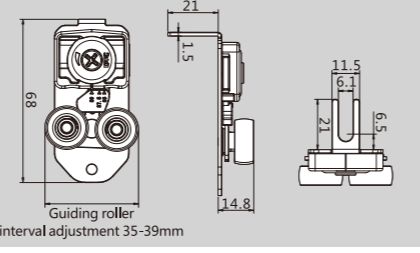
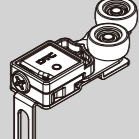
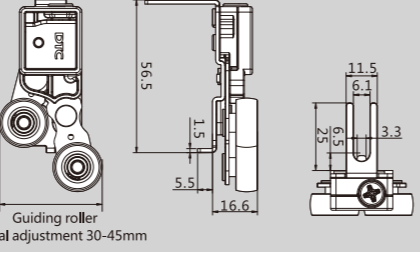
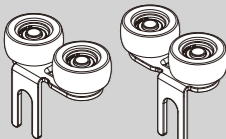
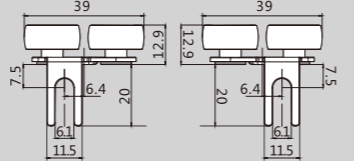
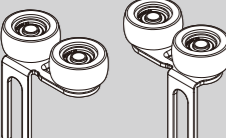
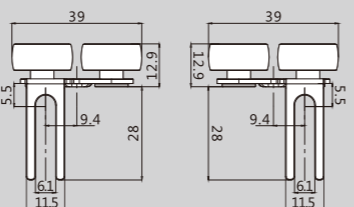
	<p>Top roller / Industrial package</p> <p>Item no. pcs/ctn</p> <p><b>OCSTL-A</b> Zinc Plated(B02) 200</p>	
	<p>Top roller / Industrial package</p> <p>Item no. pcs/ctn</p> <p><b>OCSTL-B</b> Zinc Plated(B02) 200</p>	
	<p>Top roller / Industrial package</p> <p>Item no. pcs/ctn</p> <p><b>OCSTL-C</b> Zinc Plated(B02) 200</p>	
	<p>Top roller / Industrial package</p> <p>Item no. pcs/ctn</p> <p><b>OCSTL-D</b> Zinc Plated(B02) 200</p>	
	<p>Top roller / Industrial package</p> <p>Item no. pcs/ctn</p> <p><b>CSSL-JB</b> Zinc Plated(B02) 300</p>	
	<p>Top roller / Industrial package</p> <p>Item no. pcs/ctn</p> <p><b>CSSL-JC</b> Zinc Plated(B02) 300</p>	

# TRACK-PRO

CS Series Sliding Door Bottom Roller Options

## ORDER INFORMATION

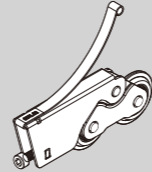
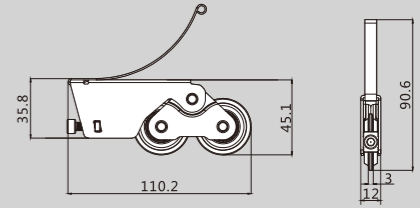
	<p>Bottom Roller / Industrial package</p> <p>Item no. pcs/ctn</p> <p><b>CSXLC</b> Zinc Plated(B02) 200</p>	
---	--	---